

UM10032

ISP1362 OTG add-on eval kit with Intel PXA250/255 IDP rev. 4

Rev. 04 — 12 October 2009

User manual

Document information

Info	Content
Keywords	isp1362; pxa250; pxa25; otg; on-the-go; usb; universal serial bus
Abstract	This document describes the ISP1362 OTG add-on eval kit for Intel PXA250/255 IDP rev. 04.

Revision history

Rev	Date	Description
04	20091012	Rebranded to the ST-Ericsson template.
03	20090203	Rebranded to the ST-NXP Wireless template.
02	20030601	Updated Table 1. Added PXA255.
01	20030501	First release.

Contact information

For additional information, please visit: <http://www.stericsson.com>

For document related queries, please send an email to: wired.support@stericsson.com

1. Introduction

The ISP1362 is a single-chip Universal Serial Bus (USB) On-The-Go (OTG) Controller, Host Controller (HC) and Device Controller (DC).

- The OTG controller is fully compliant with On-The-Go Supplement to the USB 2.0 Specification Rev. 1.0a.
- The host controller is fully compliant with Universal Serial Bus Specification Rev. 2.0; supporting data transfer at full-speed (12 Mbit/s) and low-speed (1.5 Mbit/s).
- The device controller is also fully compliant with Universal Serial Bus Specification Rev. 2.0; supporting data transfer at full-speed (12 Mbit/s).

The target applications of the ISP1362 are embedded systems, portable devices, digital still cameras, and so on. It has a 16-bit data bus for interfacing with a microprocessor and separate I/O addresses.

The ISP1362 evaluation kit with PXA250/255 is a standalone embedded system evaluation kit. Using the popular Intel PXA250 or PXA255 (previously known as the Cotulla) processor, this kit can fully utilize the bandwidth of the ISP1362.

To shorten the development time for customers, ST-Ericsson has partnered with BSQUARE to bring about an OTG add-on evaluation kit with Intel PXA250/255 IDP. During the initial partnership, BSQUARE had provided IDP revision 2.0. Over time, BSQUARE upgraded its IDP to revision 4.0. For more detailed information on the changes, refer to the BSQUARE document *PX2-IDP Spin 2 Revision Status (PX2-IDP - Spin 2 RevSts.pdf)*.

Note: Before you use the Integrated Development Platform (IDP), read *Intel PXA250 Applications Processor Integrated Development Platform (linux_user_guide_EUG-0004-0001B.pdf)* User's Guide from BSQUARE.

[Fig 1](#), [Fig 2](#), [Fig 3](#) and [Fig 4](#) show the ISP1362 OTG add-on card for PXA250/255 IDP.

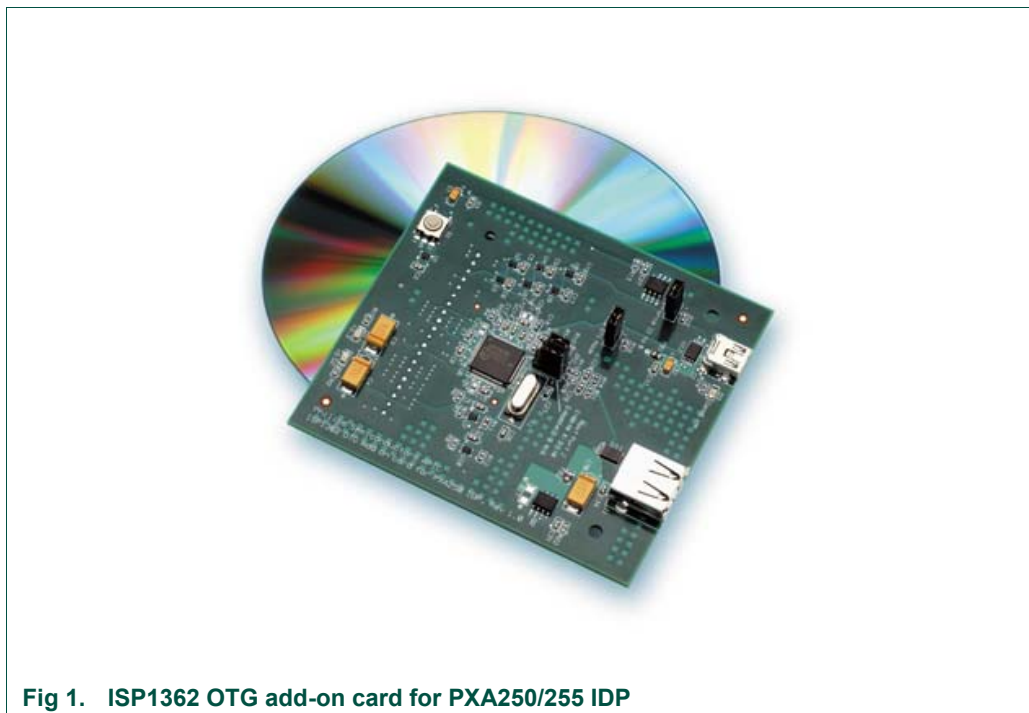

Fig 1. ISP1362 OTG add-on card for PXA250/255 IDP

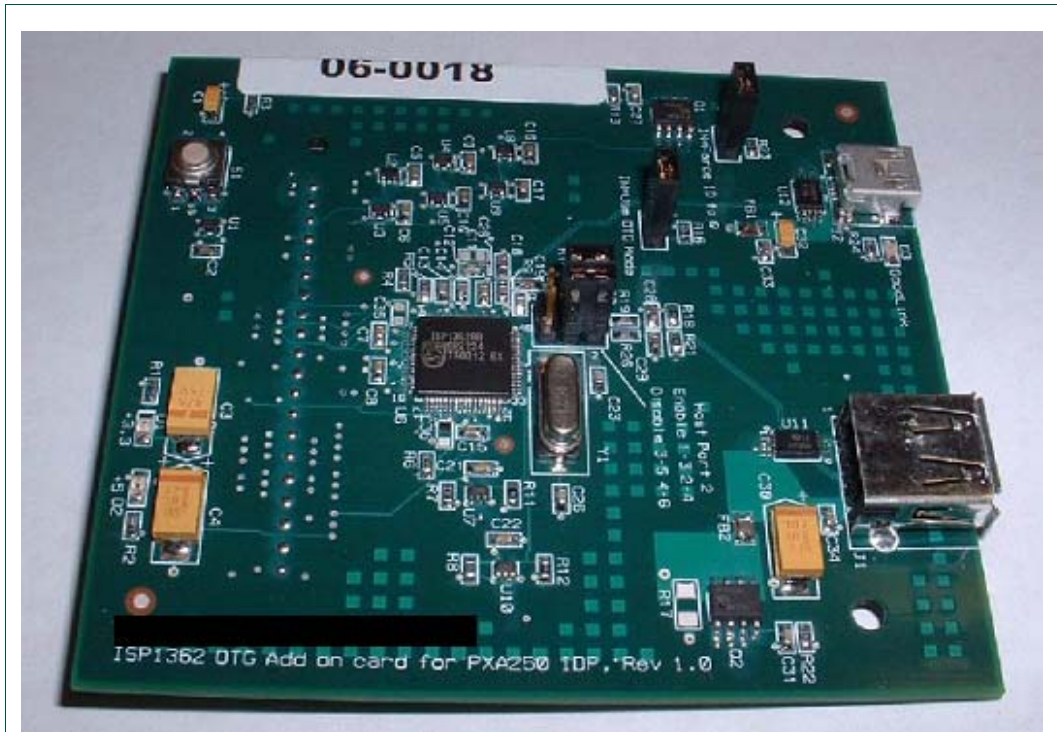

Fig 2. Top view of the ISP1362 OTG add-on card for PXA250/255 IDP



Fig 3. Side view of the ISP1362 OTG add-on card for PXA250/255 IDP

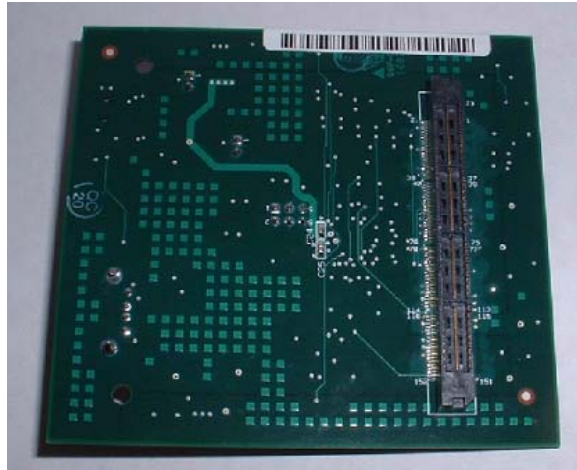

Fig 4. Bottom view of the ISP1362 OTG add-on card for PXA250/255 IDP

2. System requirements

- Two BSQUARE Linux IDP boards (version 2 or later) with the ISP1362 OTG add-on cards attached.
- One OTG cable.
- A USB speaker.



Fig 5. BSQUARE IDP version 2



Fig 6. BSQUARE IDP version 4

3. Installation

1. Copy the nk.bin file to a CompactFlash (CF) memory unit, and firmly insert the ISP1362 OTG add-on card for the PXA250/255 IDP into connector J13 on the BSQUARE IDP board.
2. Insert a PC card adapter with CF into either of the PC card slots in the BSQUARE IDP.
3. Switch ON the BSQUARE IDP, and wait for the CF memory to be reprogrammed.
4. Eject the PC card to reboot the BSQUARE IDP.

The ISP1362 evaluation kit with PXA250/255 IDP is now ready for testing.

For information on other ways to program the CF unit in BSQUARE IDP, refer to the BSQUARE document *Intel PXA250 Applications Processor Integrated Development Platform*.

3.1 Setting up the Integrated Development Platform (IDP)

1. Boot the PXA250/255 IDP.
2. Follow the instructions according to the operating system installed on the IDP.

[Fig 7](#) shows a setup of the ISP1362 OTG add-on card for PXA250/255 IDP.

Note: To play an MP3 file on an IDP, make sure the file is first uploaded to the IDP through the Ethernet. For more information on how to upload a file, refer to the BSQUARE document *Intel PXA250 Applications Processor Integrated Development Platform*.



Fig 7. Setup of the ISP1362 OTG add-on card for PXA250/255 IDP

3.2 Power supply and LED indicators

In the ISP1362 OTG add-on evaluation card, the power supply inputs, +3.3 V and +5.0 V, come from the IDP. Therefore, no other external power supply input or on-board power regulation is required.

There are LEDs on the board to indicate the power supply status:

- D1 is the +3.3 V indicator.
- D2 is the +5.0 V indicator.
- D3 is the GoodLink1 indicator for the device controller.

3.3 Connectors and jumpers

The ISP1362 OTG add-on card contains an OTG connector (J2) and a USB downstream port connector (J1) to interface with other USB peripherals. Jumper JP1 sets the OTG port to OTG or non-OTG mode, while JP2 disables the host port.

There is also a reset switch (S1) for the hardware reset of the ISP1362.

[Table 1](#) shows the jumper settings that must be configured before using the ISP1362 OTG add-on card.

Table 1. Jumper and switch settings

Jumper	Description	Setting
JP1	OTG port select	Short for OTG mode [default] Open for non-OTG mode
JP2	Host port enable	Short <1—3> and <2—4> for enabling port 2 [default] Short <3—5> and <4—6> for disabling port 2

¹ GoodLink is a trademark of ST-Ericsson.

Jumper	Description	Setting
JP3	ID pin select	Open (use ID from connector) [default] Short (force ID to zero)

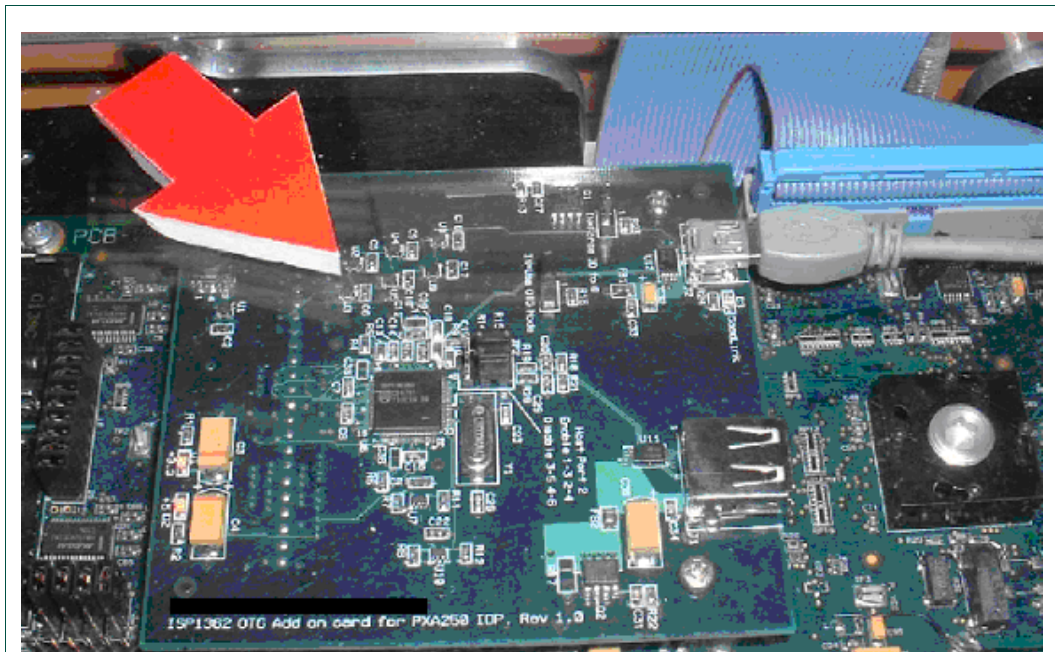

Fig 8. ISP1362 OTG add-on card on the PXA250/255 IDP

4. ISP1362 bill of materials

Table 2. Bill of materials

Quantity	Part reference	Description	Value	Rating	Manufacturer
9	C2, C5, C6, C9, C10, C16, C17, C21, C22	Capacitor, SMD MLC, 0.01 μ F, \pm 10% 50 V NPO/X7R, 0603	0.01 μ F	50 V	Generic
12	C7, C8, C13, C14, C15, C20, C24, C25, C27, C31, C33, C34	Capacitor, SMD MLC, 0.1 μ F, \pm 10% 16 V X7R, 0603	0.1 μ F	16 V	Generic
2	C23, C26	Capacitor, SMD MLC, 22 pF, \pm 10% 50 V NPO/X7R, 0603	22 pF	50 V	Generic
1	C12	Capacitor, SMD MLC, .022 μ F, \pm 10% 16 V X7R, 0603	0.022 μ F	16 V	Generic
0	C11	Capacitor, SMD MLC, .022 μ F, \pm 10% 16 V X7R, 0603	0.022 μ F	16 V	Generic
4	C18, C19, C28, C29	Capacitor, SMD, NPO/X7R 47 pF, \pm 10% 50 V 0603	47 pF	50 V	Generic
2	C1, C32	Capacitor SMD, tantalum chip, 4.7	4.7 μ F	20 V	AVX

Quantity	Part reference	Description	Value	Rating	Manufacturer
		µF, 16 V, TAJ A-CASE			
1	C30	Capacitor SMD, tantalum chip, 100 µF, 16 V, TAJ D-CASE	100 µF	16 V	AVX
2	C3, C4	Capacitor SMD, tantalum chip, 47 µF, 16 V, TAJ D-CASE	47 µF	16 V	AVX
1	U6	ISP1362 USB OTG controller	-	-	ST-Ericsson
2	JP1, JP3	Header – 1 x 2 .025SQ PIN .100 centers	-	-	Generic
1	JP2	Header – 2 x 3 .025SQ PIN .100 centers	-	-	Generic
1	J3	High-speed terminal, MIT series, 50 Ω, 152 contact, 0.025 in spacing, 8 mm board spacing	-	-	Samtec
1	J1	USB Type A connector, no panel grounding ears	-	-	Tyco/Amp
1	J2	Conn, Mini-AB USB, surface mount	-	-	Acon
2	U11, U12	Diode SMD, Dual USB transient suppressor	-	-	Texas instruments
2	FB1, FB2	Ferrite bead, SMD, with copper pattern heat sink	-	2 A	muRata electronics
4	M1, M2, M3, M4	Shunt, single position, .100 center, black	-	-	Samtec
1	S1	Switch, SMD, momentary, NO, w/ground tab	-	-	Omron
4	U3, U4, U5, U9	IC SMD single OR gate 5 pin	-	-	Fairchild
1	U1	UHS 2-input AND gate, SC70 5 lead	-	-	Fairchild
2	U7, U10	IC SMD, UHS buffer W/3 state out NC7SZ125P5 SC70, 5 lead	-	-	Fairchild
2	U2, U8	NC7SZ04P5 single gate inverter	-	-	Fairchild
2	D1, D2	LED SMT 0805 red	-	-	Lumex
1	D3	LED SMT 0805 green	-	-	Lumex
0	R17	Resistor, SMD, spare, 1206	0	-	No mfg-etched part
4	R9, R10, R19, R20	Resistor, SMD, fixed, film, chip, 22.0 Ω, ±5%, 1/16 W, 0603	22	1/16 W	Generic
5	R3, R4, R5, R13, R22	Resistor, SMD, fixed, film, chip, 10 K, ±5%, 1/16 W, 0603	10 K	1/16 W	Generic

Quantity	Part reference	Description	Value	Rating	Manufacturer
7	R6, R7, R8, R14, R15, R16, R23	Resistor, SMD, fixed, film, chip, 100 K, $\pm 5\%$, 1/16 W, 0603	100 K	1/16 W	Generic
2	R18, R21	Resistor, SMD, fixed, film, chip, 15.0 K, $\pm 5\%$, 1/16 W, 0603	15 K	1/16 W	Generic
2	R1, R24	Resistor, SMD, fixed, film, chip, 470 Ω , $\pm 5\%$, 1/16 W, 0603	470	1/16 W	Generic
2	R11, R12	Resistor, SMD, fixed, film, chip, 4.70 K, $\pm 5\%$, 1/16 W, 0603	4.7 K	1/16 W	Generic
1	R2	Resistor, SMD, fixed, film, chip, 680 Ω , $\pm 5\%$, 1/16 W, 0603	680	1/16 W	Generic
2	Q1, Q2	MOSFET, P-channel, 30 V Vds	-	-	Fairchild
1	Y1	12 MHZ, SM, crystal	-	-	Citizen
1	PCB, ST-Ericsson ISP1362 USB On-The-Go expansion board for BSQUARE IDPs				

5. ISP1362 OTG add-on evaluation card schematics

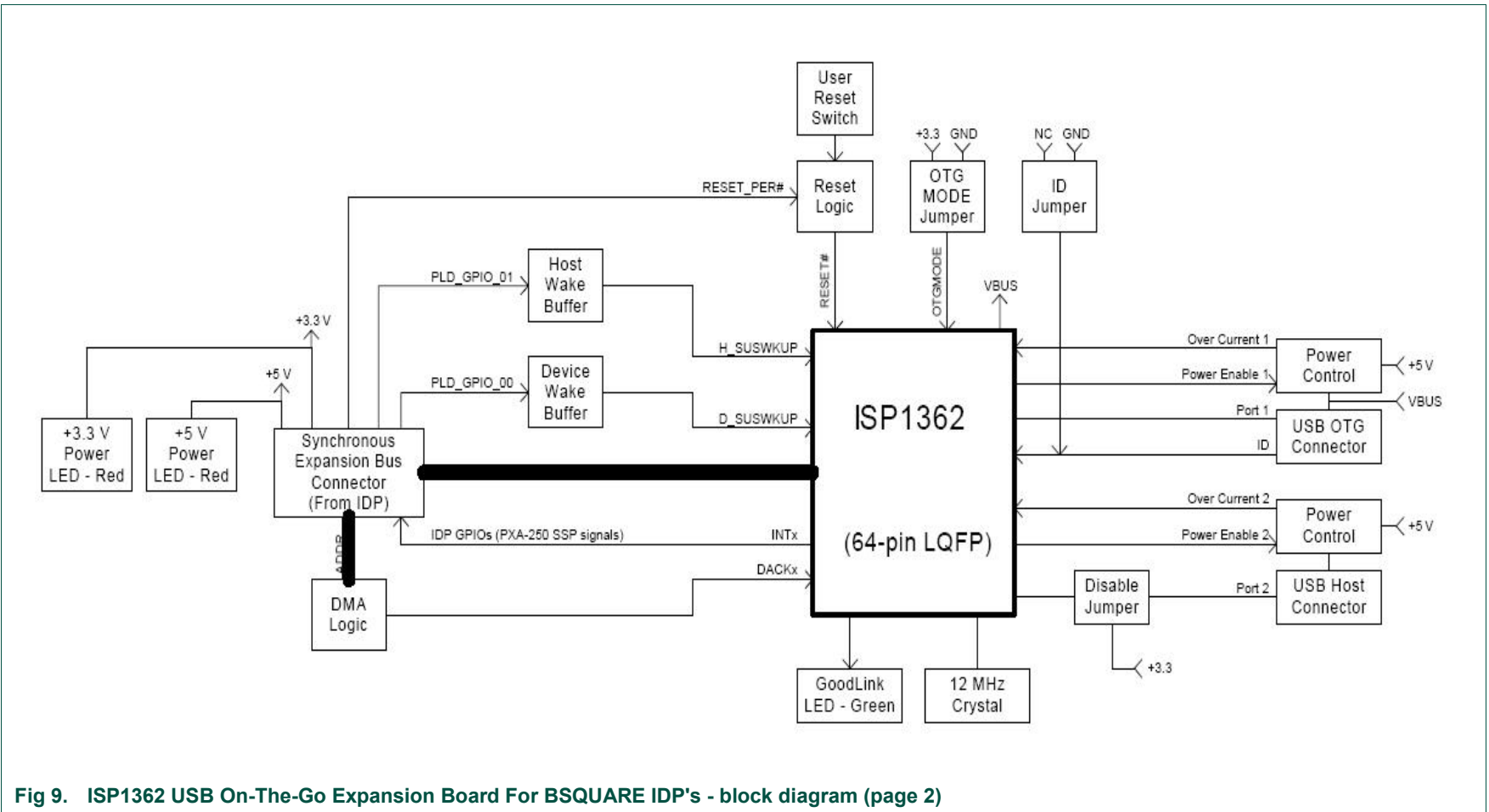

Fig 9. ISP1362 USB On-The-Go Expansion Board For BSQUARE IDP's - block diagram (page 2)

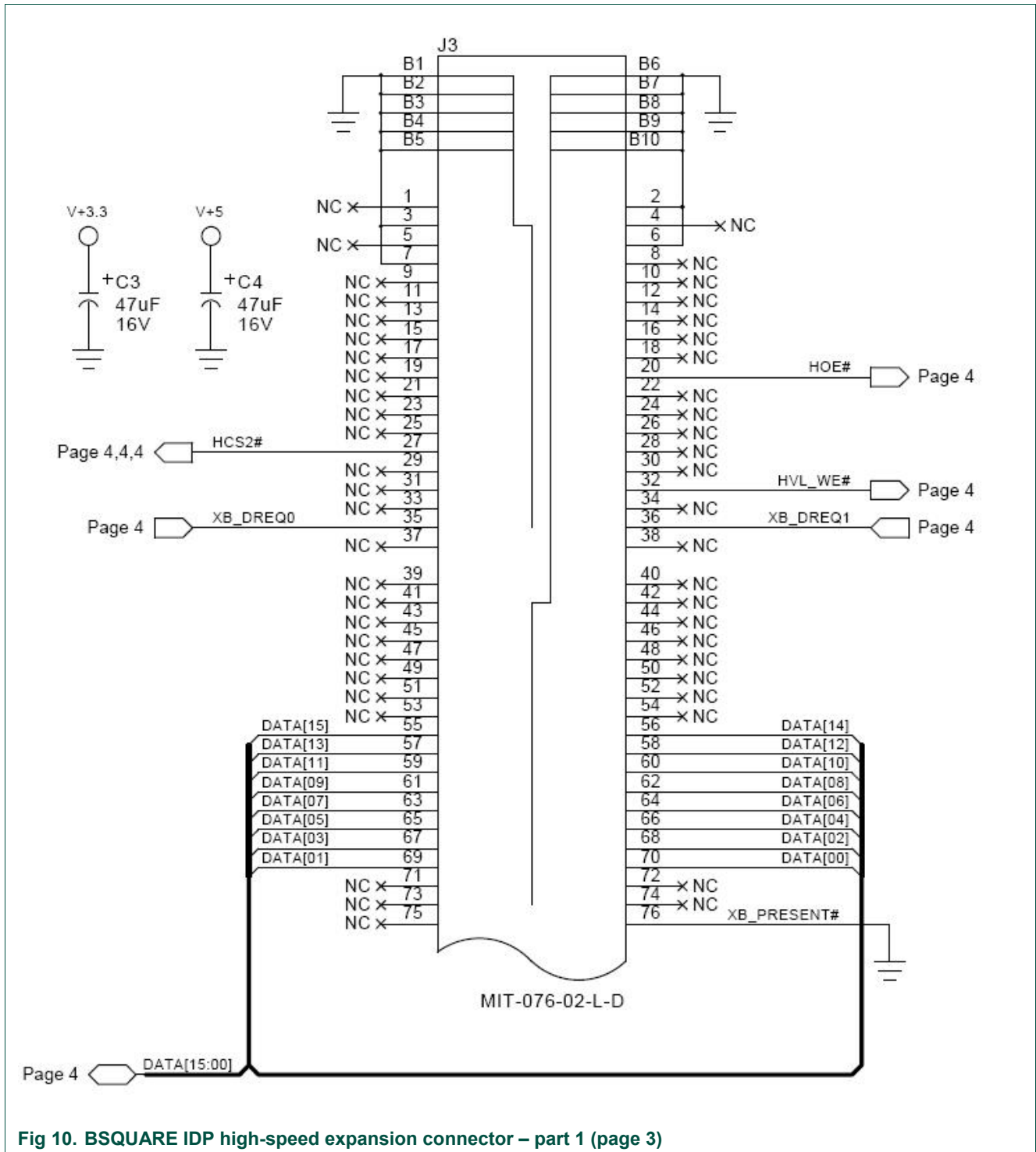

Fig 10. BSQUARE IDP high-speed expansion connector – part 1 (page 3)

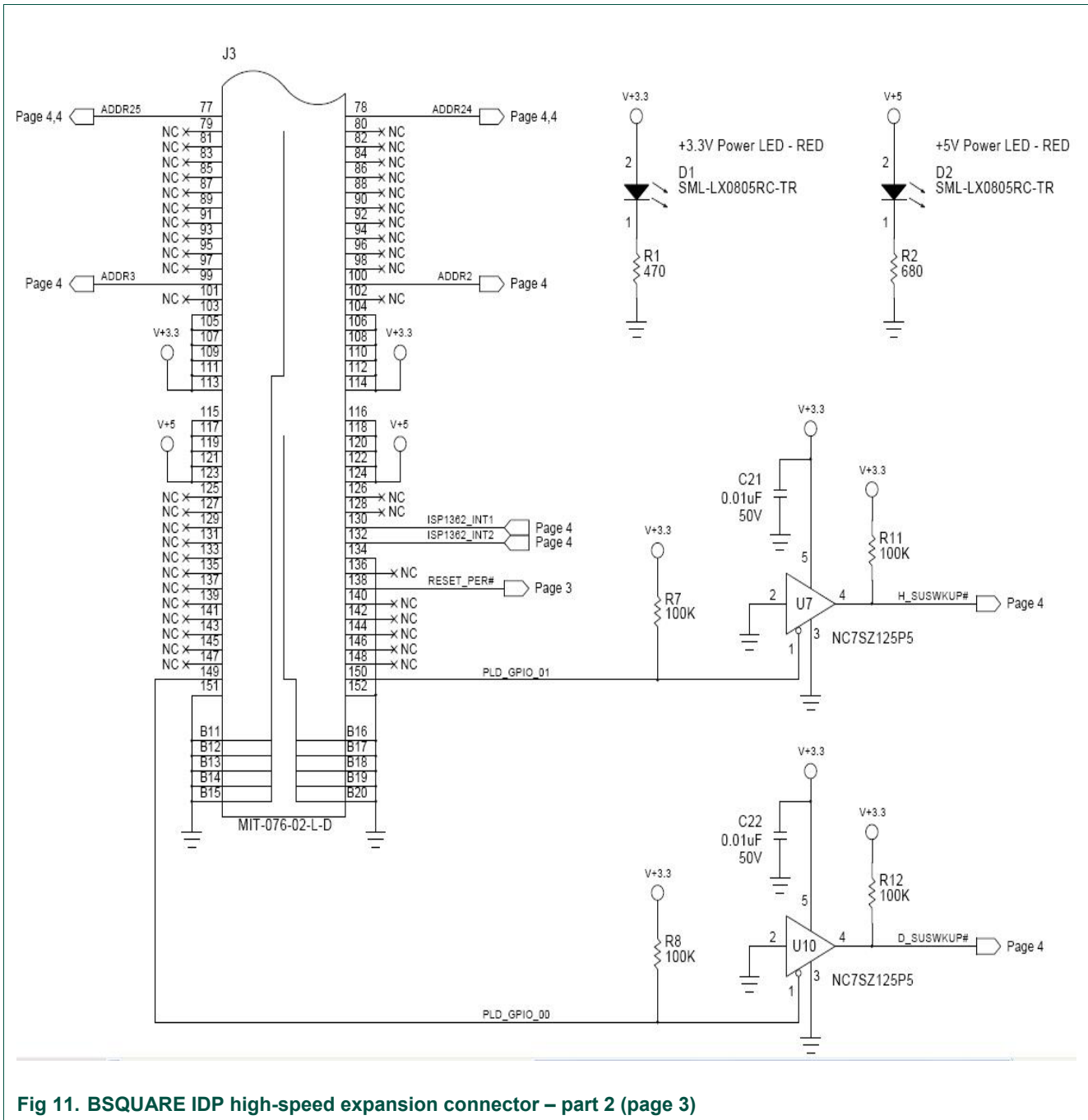

Fig 11. BSQUARE IDP high-speed expansion connector – part 2 (page 3)

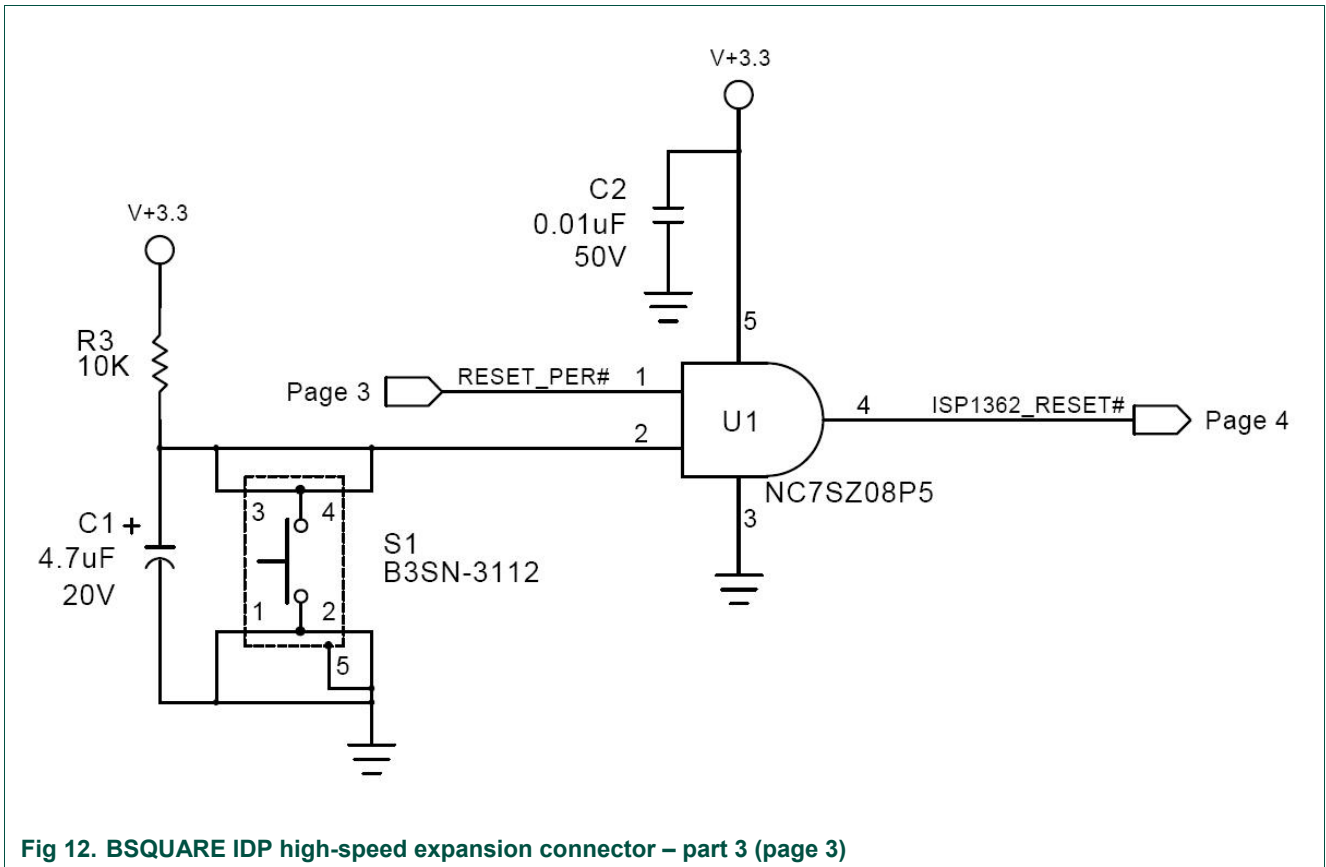

Fig 12. BSQUARE IDP high-speed expansion connector – part 3 (page 3)

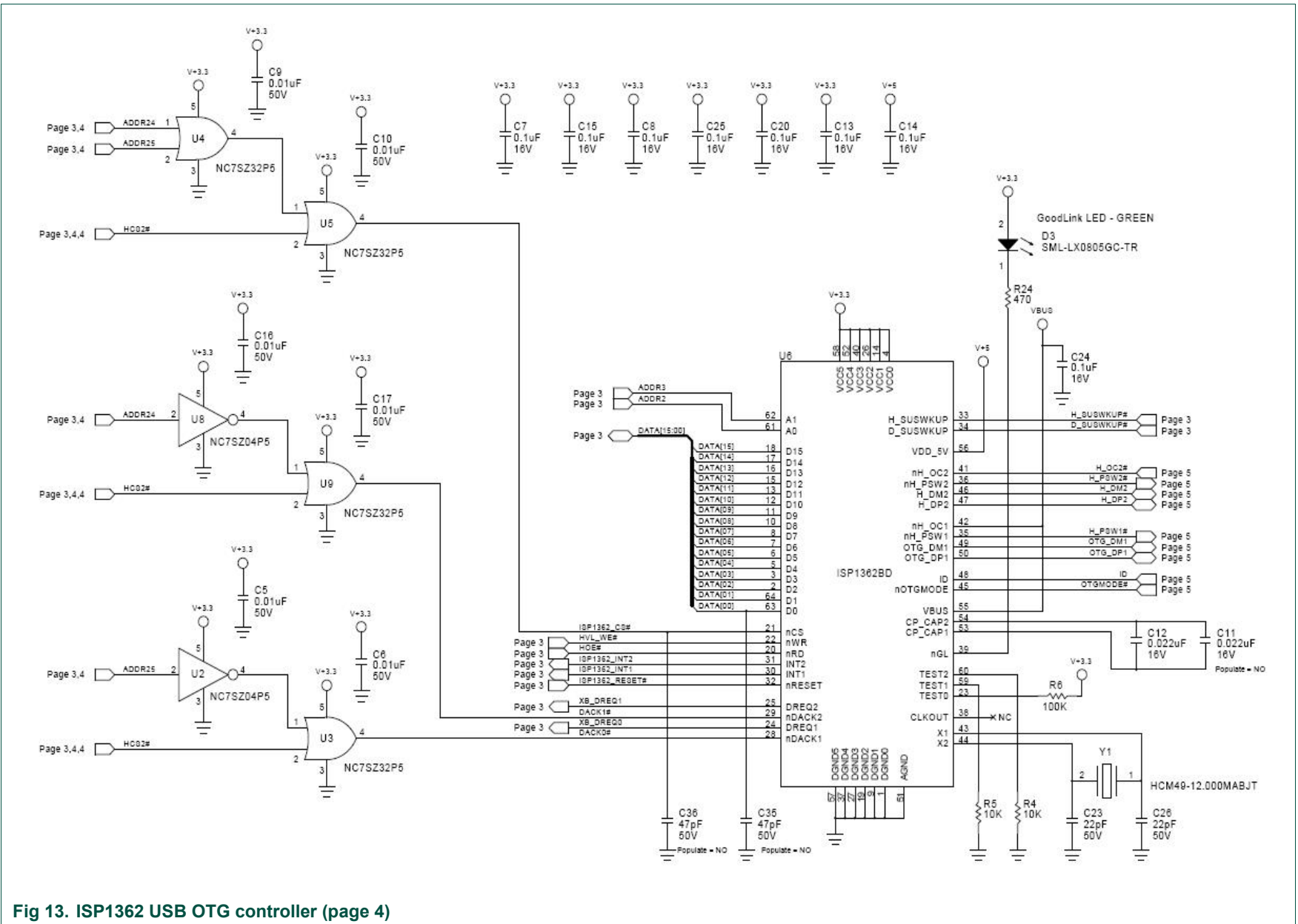

Fig 13. ISP1362 USB OTG controller (page 4)

For DMA accesses, use the following address ranges. This will generate the DMA Acknowledge signals needed. Processor uses CS2#.

PIO Address Map: 0000 0000h to 00FF FFFFh.

DMA Channel 0 Address Map: 0200 0000h to 02FF FFFFh.

DMA Channel 1 Address Map: 0100 0000h to 01FF FFFFh.

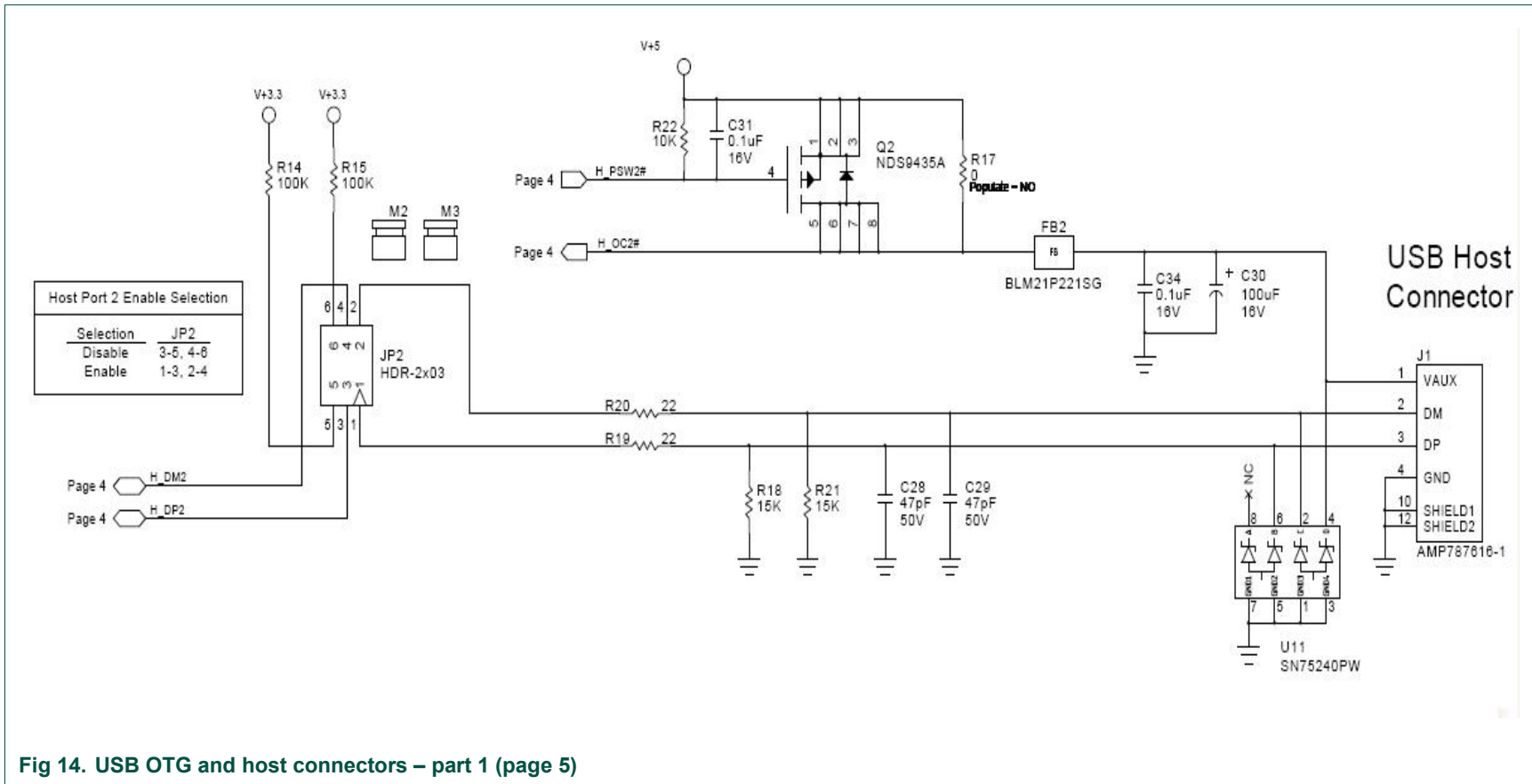

Fig 14. USB OTG and host connectors – part 1 (page 5)

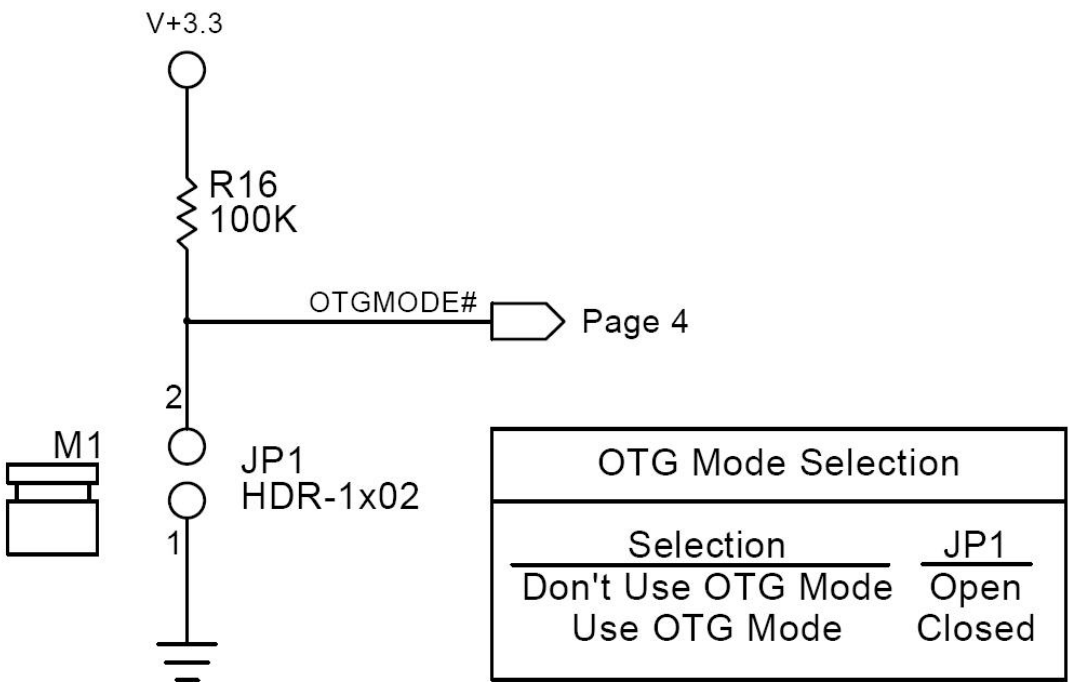

Fig 15. USB OTG and host connectors – part 2 (page 5)

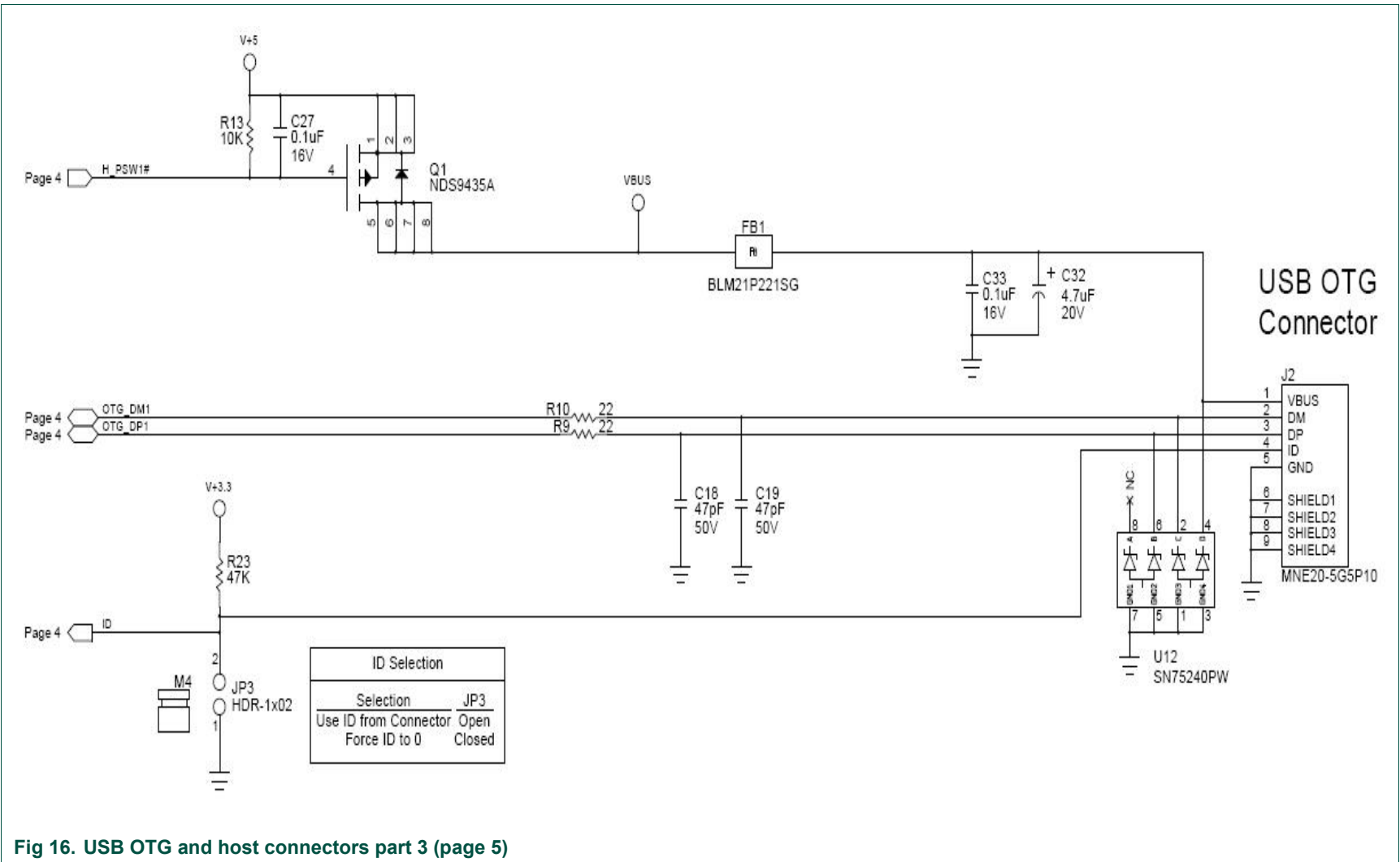

Fig 16. USB OTG and host connectors part 3 (page 5)

6. References

- [1] ISP1362 Single-chip USB On-The-Go controller data sheet
- [2] ISP1362 Linux Stack user manual
- [3] Universal Serial Bus Specification Rev. 2.0
- [4] On-The-Go Supplement to the USB 2.0 Specification Rev. 1.0a
- [5] Intel PXA250 Applications Processor Integrated Development Platform User's Guide from BSQUARE (linux_user_guide_EUG-0004-0001B.pdf)

7. Legal information

Please Read Carefully:

The contents of this document are subject to change without prior notice. ST-Ericsson makes no representation or warranty of any nature whatsoever (neither expressed nor implied) with respect to the matters addressed in this document, including but not limited to warranties of merchantability or fitness for a particular purpose, interpretability or interoperability or, against infringement of third party intellectual property rights, and in no event shall ST-Ericsson be liable to any party for any direct, indirect, incidental and or consequential damages and or loss whatsoever (including but not limited to monetary losses or loss of data), that might arise from the use of this document or the information in it.

ST-Ericsson and the ST-Ericsson logo are trademarks of the ST-Ericsson group of companies or used under a license from STMicroelectronics NV or Telefonaktiebolaget LM Ericsson.

All other names are the property of their respective owners.

© ST-Ericsson, 2009 - All rights reserved

Contact information at www.stericsson.com under Contacts

www.stericsson.com

8. Contents

1.	Introduction	3
2.	System requirements	5
3.	Installation	6
3.1	Setting up the Integrated Development Platform (IDP).....	6
3.2	Power supply and LED indicators	7
3.3	Connectors and jumpers	7
4.	ISP1362 bill of materials	8
5.	ISP1362 OTG add-on evaluation card schematics	10
6.	References	19
7.	Legal information	20
8.	Contents	21